

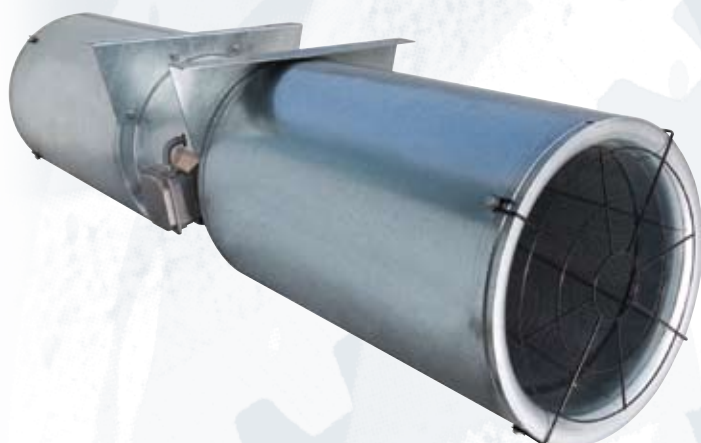

AXIAL JET FANS

TJHT Series



Officially approved to EN12101-3 standard (certificate number 0370-CPD-0672)



Officially approved to EN12101-3 standard (certificate number 0370-CPD-0673)



Officially approved to EN12101-3 standard (certificate number 0370-CPD-0775)

Application

Jet fans to induce air movement in enclosed car parking, tunnels and large spaces.
TJHT: models for ventilation and emergency smoke operation at F400, F300 or F200.

Description

Diameter from 315 to 630 mm.
Fully reversible impeller for airflow in both directions.
Impeller is **cast aluminum alloy** in accordance with **EN 1706**, and balanced in accordance with **ISO 14694: G 6.3**.
Fan duct and 2 mounting feet are **steel** in accordance with EN 10130-99, and **hot dip galvanized** in accordance with **EN 1461: 1999**.
Fan external electrical terminal box.
Two circular sound attenuators in **galvanized sheet steel, with flared inlet and acoustic media**.
Supplied with inlet and outlet **steel guard**.
Impeller with 6 blades at 41° pitch angle.
Complete fan assembly independently tested and approved in accordance 0370-CPD-0775 with **EN12101-3** at F400, F300 or F200.
For transportation, size up to 400 is supplied complete; size from 450 to 630 is supplied complete or in 3 pieces (silencer/fan/silencer).

Motors

IEC, from 80 to 160. Three phase 400/50Hz. IP55. Class H insulation at F400, F300 or Class F at F200.
Two speed 2/4 pole Dalhander winding.
Maximum ambient temperature 40°C.

On request

Version single speed 2 pole for F400, F300 or F200.
Version with inlet guard and **steel discharge deflector** for uni-direction airflow.
Version with inlet and outlet **steel discharge deflector** for reversible airflow.
Version with IP65 isolator in place of electrical Terminal box, suitable for F200 or F300. Factory fitted.
External painting to RAL colour.

TJHT

Jet fans

APPLICATIONS



Parkings



Tunnels



F400-120



F300-120



F200-120

External terminal box



External terminal box for ease of connection

Two protection guards fitted as standard

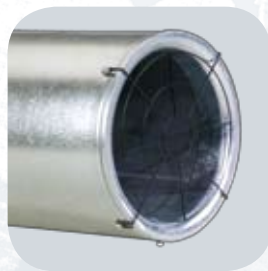

Air protection guard to mount at the inlet or outlet side

Optional isolator



Electrical Isolator fitted to fan for security (available only for F200 or F300)

Optional deflector

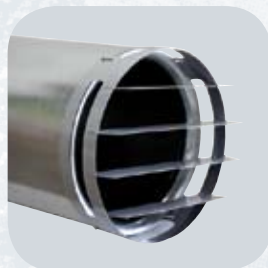

Optional deflector on outlet for uni direction, or inlet and outlet for reversible

Reference

T	J	H	T	/	2	-	6	3	0	C	15kW	F400	400V	50Hz
1	2	3	4	5	6	7	8							

- 1 - : Serie
- 2 - : Motor speed (poles)
- 3 - : Nominal diameter
- 4 - : C = terminal box (standard). I = isolator (optional)
- 5 - : Motor power in kW
- 6 - : Emergency operation designation
- 7 - : Nominal electrical supply
- 8 - : Frequency (Hz)

Technical characteristics

Before installation check that the product electrical characteristics listed on the data plate label (Voltage, power, frequency etc) match those of the intended electrical supply.

Model	Speed (poles)	Speed (r.p.m.)	Thrust (N)	Airflow (m ³ /h)	Air velocity (m/s)	Motor* (kW)	Maximum absorbed current (A)	Sound level** (LpA)		Weight (Kg)
								Form A***	Form B***	
REVERSIBLE - 1 speed 2 POLE										
TJHT/2-315-C	2	2790	24	4.500	16	0,75	1,57	71	64	61
TJHT/2-355-C	2	2810	40	6.500	18	1,1	2,32	74	67	80
TJHT/2-400-C	2	2875	60	9.000	20	1,5	3,01	79	71	93
TJHT/2-450-C	2	2875	85	12.075	21	2,2	4,48	82	74	133
TJHT/2-500-C	2	2930	150	17.850	25	4	7,5	85	78	165
TJHT/2-560-C	2	2940	239	25.200	28	7,5	13,6	88	81	220
TJHT/2-630-C	2	2935	390	36.225	33	15	27	90	83	290
REVERSIBLE - 2 speed 2/4 POLE										
TJHT/2/4-315-C	2/4	2820/1400	24	4.500	16	0,8/0,2	1,91/0,6	71/56	64/49	61
TJHT/2/4-355-C	2/4	2810/1390	40	6.500	18	1,1/0,25	2,41/0,75	74/59	67/52	80
TJHT/2/4-400-C	2/4	2850/1460	60	9.000	20	1,5/0,37	3,54/1,25	79/64	71/56	94
TJHT/2/4-450-C	2/4	2870/1470	85	12.075	21	2,2/0,75	4,63/1,54	82/67	74/59	134
TJHT/2/4-500-C	2/4	2900/1470	150	17.850	25	4,4/1,1	8,59/2,79	85/70	78/63	166
TJHT/2/4-560-C	2/4	2930/1470	239	25.200	28	8/2	15,3/4,83	88/73	81/66	223
TJHT/2/4-630-C	2/4	2950/1470	390	36.225	33	16/4	30,5/9,6	90/75	83/68	311

* May depends on motor used.

** Sound pressure at 3m, hemispherical propagation, in free field conditions, for comparison.

*** Form A: Motor over impeller / Form B: Impeller over Motor (unidirection).



■ Dimensions (mm)

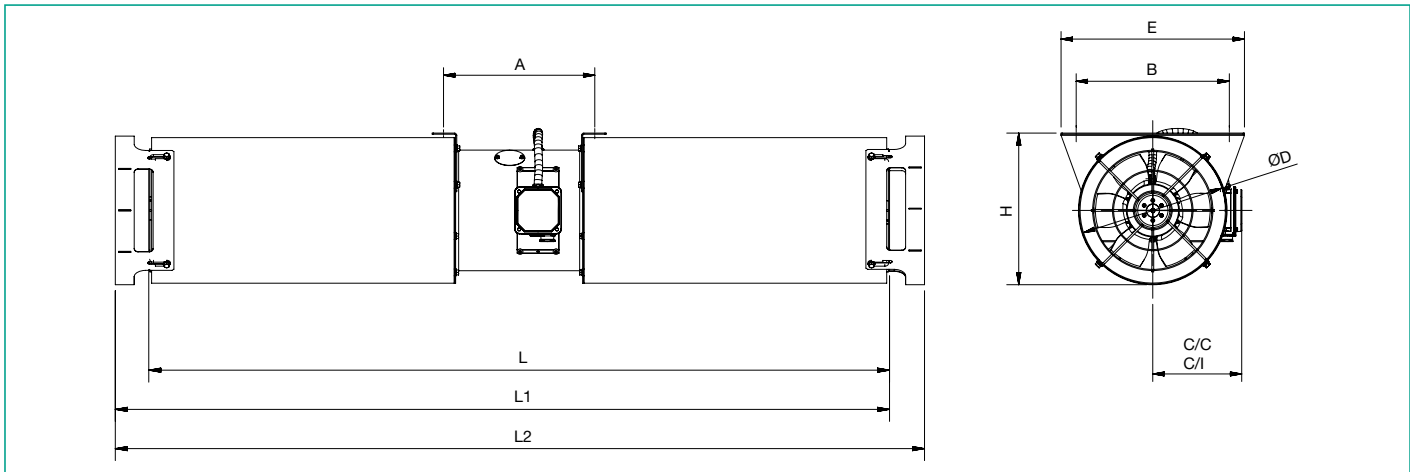

L: without deflector
 L1: for unidirection, with 1 deflector
 L2: for reversible, with 2 deflector
 C/C: version with terminal box (standard)
 C/I: version with isolator (optional)

Model	A	B	C/C	C/I	D	E	H	L	L1	L2
315	400	405	235	289,5	385	485	397	1959	2002	2225
355	400	445	260,5	309	425	525	437	1959	2002	2225
400	439	506	287	336	486	586	498	1999	2040	2263
450	539	556	313,5	362,5	536	636	548	2499	2542	2767
500	549	620	343,5	392,5	600	700	612	2499	2551	2816
560	669	680	376	425	660	760	672	3019	3072	3375
630	769	750	422	480	730	830	742	3119	3177	3539

■ Acoustic characteristics

Sound power levels, ref 10^{-12} watts. Tested in accordance with ISO 13347:2004

2 pole

Form A	63	125	250	500	1000	2000	4000	8000	LwA
315	59	68	84	73	75	76	72	66	86
355	62	71	87	76	78	79	75	69	89
400	68	76	92	80	82	81	76	69	93
450	70	78	95	84	86	86	83	76	97
500	73	82	98	87	89	90	86	80	100
560	74	83	100	90	92	94	92	86	102
630	80	89	105	94	96	97	93	87	107

Form B	63	125	250	500	1000	2000	4000	8000	LwA
315	59	65	75	67	70	71	68	63	79
355	62	68	78	70	73	74	71	66	82
400	67	73	83	74	76	76	72	66	85
450	70	76	85	77	81	82	78	73	89
500	73	79	89	81	84	85	82	77	93
560	75	81	90	83	88	90	87	83	96
630	80	86	96	88	91	92	89	84	100

4 pole

Form A	63	125	250	500	1000	2000	4000	8000	LwA
315	44	53	69	58	60	61	57	51	71
355	47	56	72	61	63	64	60	54	74
400	53	61	77	65	67	66	61	54	78
450	55	63	80	69	71	71	68	61	82
500	58	67	83	72	74	75	71	65	85
560	59	68	85	75	77	79	77	71	87
630	65	74	90	79	81	82	78	72	92

Form B	63	125	250	500	1000	2000	4000	8000	LwA
315	44	50	60	52	55	56	53	48	64
355	47	53	63	55	58	59	56	51	67
400	52	58	68	59	61	61	57	51	70
450	55	61	70	62	66	67	63	58	74
500	58	64	74	66	69	70	67	62	78
560	60	66	75	68	73	75	72	68	81
630	65	71	81	73	76	77	74	69	85

